

# Installation and Operations Manual

## PoweRack 230 Premises Powering Unit



SEI Incorporated  
5115 Pegasus Court  
Suite Q  
Frederick, Md 21704  
Phone 301-694-9601  
Fax 301-694-9608  
Email [info@seipower.com](mailto:info@seipower.com)  
Web <http://www.seipower.com>

19-0043-001 REVB

## TABLE OF CONTENTS

Table of Contents.....	1
Table of Illustrations.....	1
Safety Information.....	1
Description.....	2
Technical Specifications .....	2
Installation Instructions .....	4
Startup and Checkout .....	6
Theory of Operation .....	7
Repair and Maintenance.....	10
Troubleshooting.....	11

## TABLE OF ILLUSTRATIONS

PoweRack230.....	Figure 1.....	3
Functional Block Diagram .....	Figure 2.....	7
Models PR230-24/48.....	Appendix A .....	13
U Interface Connections.....	Appendix B Figure 1 .....	14
S/T Interface Connections.....	Appendix B Figure 2 .....	15
PR230 Right Side Connections.....	Appendix B Figure 3 .....	16

## SAFETY INFORMATION

Always insure that the person assigned to the job can perform the job safely.

Always lift all equipment properly.

Always disconnect commercial power and remove the battery fuse before working on the unit.

Always replace the batteries with batteries of the same type and style.

**DO NOT** work on this equipment during an electrical storm.

**DO NOT** work in locations where there is condensing moisture.

The AC wall outlet shall be installed near the equipment and easily accessible.

## DESCRIPTION

- 1.1 The PowerRack230 is an integrated unit designed to provide high density ISDN CPE, power and NT1 racking. The unit comes equipped with rectifiers providing 140 watts of power. The PR230 is designed for use with Lucent's P230 NT1 circuit cards. There is capacity for a quantity of 12 or 24 NT1p-230's that provide power and signal for 24 to 48 multipoint phones. Each P-230 is a PC card NT1 with single "U" input.

Input connections for the "U" Interface are made via a 25 Pair connector on the left side of the unit. The remaining two 25 pair connectors provide the "S/T" output connections for the terminals.

On the right wall of the card cage is a power connectors, which interface with the power unit (below) and additional caging (above) when needed (See Figure 1.) Thermal fusing devices known as PTCs have been employed in the systems circuit design for the protection of power connections for the NT1B-300's and multipoint terminals.

## TECHNICAL SPECIFICATIONS

	<b>PR230-24 &amp; PR230-48</b>
<u>Electrical Input</u> Voltage/Frequency	92-132,176-264 VAC/47-63 Hz
<u>Electrical Output</u> Voltage/Current	37-48 Vdc/ 2.5 amps DC
<u>Dimensions W x D x H (Inches)</u>	
PR230-24	19.00 x 7.5 x 7
PR230-48	19.00 x 7.5 x 14
<u>Environmental Temp</u> Operating/Storage	0 deg C to +50 deg C/-25 deg C to +50 deg C
<u>Humidity</u>	95% non-condensing

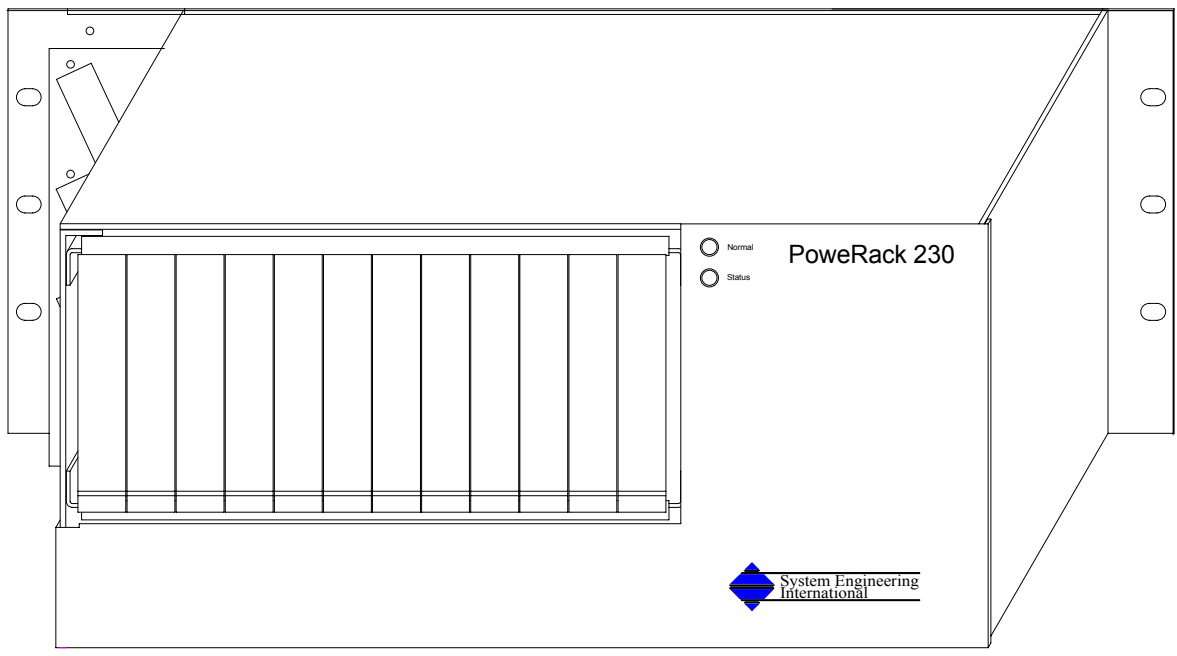

PoweRack230-24

Figure 1

# INSTALLATION INSTRUCTIONS

## 2.1 GENERAL

- 2.1.1 The installation section of this manual will provide the necessary information for room requirements, proper inspection and installation, as well as instructions on checking and bringing the PoweRack230 on line for use.

## 2.2 Unpacking and Inspection

- 2.2.1 This equipment has been fully tested and inspected prior to shipment. Although it has been packed in accordance with good commercial practices, this does not preclude damage in transit.
- 2.2.2 The following actions should be taken on receipt of the equipment.
- a. Visually inspect the shipping container for damage. If damaged, request that the carrier inspect the shipment.
  - b. Unpack the shipping container and remove the unit from the packaging. Inspect the unit for visible damage.
- 2.2.3 If a claim for damages is to be made it should be filed promptly with the transportation company. In addition notify SEI Corporation within two days of delivery. SEI Corporation will advise the customer of any further procedures that may be required including an RMA number in the event that the unit has to be returned to the factory for repair.
- 2.2.4 Make sure that the following items are included inside the package:
- a. One PoweRack230 unit.
  - b. Power interconnection cable(s) (depending on system configuration.)
  - c. One warranty card.
  - d. One Equipment Manual.
  - e. Mounting Instructions.

## 2.3 Electrical Power Requirements

### 2.3.1 PR230

- 2.3.1.1 All units are shipped from the factory for use with 115 VAC. In the event that operations at 230 VAC is required please notify the factory.
- 2.3.1.2 Each unit requires a separate NEMA 5-15R receptacle with a maximum of twelve units per 20 amp service.
- 2.3.1.3 A standard 6 foot power cord NEMA 5-15 plug is supplied comes attached to each unit.

### 2.3.2 Load Specifications

- 2.3.2.1 The PR230 series will handle phones in both point to point configurations and in multipoint configurations.
- 2.3.2.2 In point to point configurations telephones greater than three watts off-hook load may be used.
- 2.3.2.3 In multipoint configurations it is not recommended to use 970, 65XX, 75XX or equivalent telephones.

## 2.4 Room Requirements

- 2.4.1 A clean dry room environment should be picked for the installation of the PoweRack230. The power configuration of the PoweRack230 will produce 40 Btu's of heat when fully loaded.

## 2.5 Mounting Instructions

- 2.5.1 When mounting the PoweRack230 keep in mind the weight of the unit can be as little as 15 lbs.
- 2.5.2 The PoweRack230 is designed to mount to a rack or wall without further requirements for additional mounting kits. For wall mounting a user supplied 3/4-inch plywood backboard or equivalent is required. The PoweRack230 should be fastened to the backboard using number ten wood screws for each unit. A number 27 drill should be used to provide a pilot hole for the screws. All of the screws should be tightened with a torque of 30 inch pounds minimum and 34 inch pounds maximum.
- 2.5.3 Whether the unit is to be rack or wall mounted it should be mounted vertically in a clean dry area where the ambient temperature does not exceed 50 degrees C (120 degrees F)
- 2.5.4 It is important that ventilation for the unit be provided. Leave adequate space above and below the unit so that unrestricted airflow is allowed to the unit. It is suggested that 5 inches of space be allocated around the top of the unit.
- 2.5.5 The PoweRack230 is supplied with mounting angles suitable for 19" standard, racks or wall mounting. Optional 23", and 25" angles for wider racks are available.
- 2.5.6 The mounting slots on each rack adapter are spaced in conformance with EIA standard RS-310-B.

## 2.6 Installing the NT1P230

- 2.6.1 The caging each power unit holds 12 NT1P230's (minimum configuration) or as much as 24 NT1P-230's (maximum configuration.) In either case the NT1's are installed by inserting each NT1 into the number of positions desired.

# START UP AND CHECKOUT

## 3.1 General

- 3.1.1 When the unit is shipped from the factory the PowerRack230 is configured for 115 VAC operation. If operation at 230 VAC is required, please notify the factory.

## 3.2 Power Checkout

- 3.2.1 Check out the following before plugging in the unit. Make sure that the unit(s) are being plugged into their own circuit breakers. Make sure that there are no other loads on these breakers.
- 3.2.2 With the breaker in the on position measure the utility voltage at the service outlet. The voltage should be between 92 to 132 volts.

## 3.3 Power Up Procedure

- 3.3.1 Once the unit is mounted, attach the first "U" 25 pair connector on the left side of the unit. It is suggested that telco connectors, 25 pair, male cables be used with the termination end readied for punch down connection.
- 3.3.2 The "U" input connector provides the signal to the NT1's. Each 25 pair input distributes the signal to 12 NT1's.
- 3.3.3 The NT1-230 "S/T output connectors" are 2 25 pair amphenol connectors located on the left side of the unit under the input connector..
- 3.3.4 Install the first NT1 in its appropriate slot, making sure that the pin connections are made at the rear of the unit.
- 3.3.5 3.3.6 Connect the power cord and supply power to the unit. You should have a green led indication on the front of the unit. If any problems arise, consult the troubleshooting guide in the installation manual.
- 3.3.6 Connect the remaining NT1P230's and "S/T output cable(s)" to the terminal(s).
- 3.3.7 Wait about 2 minutes from initial power on before performing the following check.
- 3.3.8 Disconnect the AC power cord from the unit. The Green normal indicator should go off. And the Red Alarm Indicator should be on. This indicates loss of AC power and the system is on battery.
- 3.3.9 If all of the above checks are completed and if the results obtained are satisfactory, then the system is ready to be connected to operational loads.

# THEORY OF OPERATION

## 4.1 Theory of Operation

4.1.1 The following will provide you with an outline of operations of the system.

4.1.2 The following is a list of the modules, which are found in the PowerRack300.

- a. Rectifier/Charger
- b. LVD and Alarm Card
- c. Battery Modules
- d. Backplane and Distribution
- e. NT1 Card Cage
- f. Distribution and Connectors

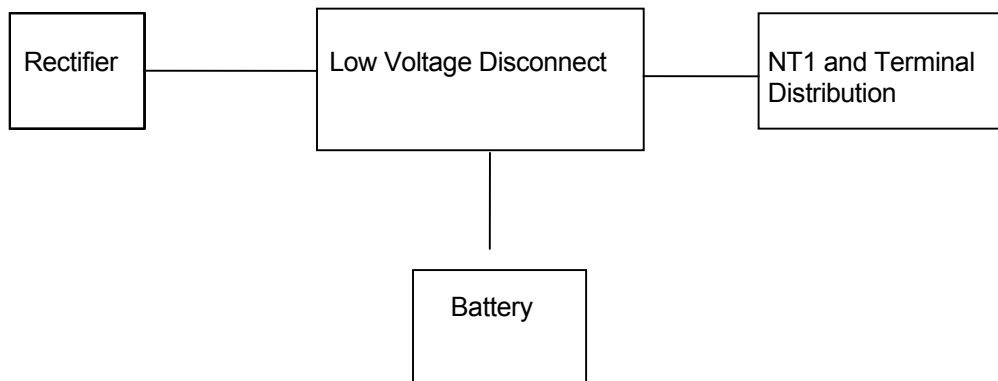

Functional Block Diagram PR230

Figure 2

## 4.2 Rectifier/Charger

4.2.1 The Rectifier/Charger is a module providing 140 watts of DC power to the PowerRack230 and the attached terminals. The rectifier(s) are sized to power as many as 24 Lucent Technologies 8510 terminals (12 in point to point minimum configuration) in a multi-point arrangement or as many as 48 Lucent Technologies 8510 terminals (24 in point to point maximum configuration) in a multi-point arrangement. The 8510 phone power required is 1.8 watts active power. The NT1P230 power required is .65 watts active power.

4.2.2 AC Power is applied to the unit on the right side. A fuse located at the front of each of the rectifier/charger, inside the unit, protects their input. The output of the rectifier/charger is located on the right side of the unit and is distributed to the racking below through an 8-pin power cable.

### 4.3 LVD and Alarm Card

4.3.1 The LVD and Alarm Card have the following functions:

- a. Distribution of the DC power
- b. Local and Remote Alarms
- c. Low Voltage Disconnect Function

#### 4.3.2 DC Power Distribution

4.3.2.1 The LVD, which is integrated into the main distribution board mounted inside of the unit, takes power in from the rectifier/charger. Power is then distributed to the battery modules, distribution board, and racking.

#### 4.3.3 Local and Remote Alarms

4.3.3.1 Local indicators are located on the front of the unit. These indicators are Normal and Status. The Local Status indicator will let you know one of two things has happened.

- a. First that commercial AC power source has failed. This is an indication that the unit is on batteries.
- b. The second indication is that the output of the rectifier/charger(s) has failed and the unit is on batteries.

4.3.3.2 There is a reference diagram Appendix B figure 3 showing the pin out for the remote alarm connector. SEI provides as an option a remote alarm module. (Model RA-1)

#### 4.3.4 Low Voltage Disconnect Function

4.3.4.1 The low voltage disconnect function will disconnect the battery when the voltage drops below a preset limit. This is done so that excessive drain on the battery does not occur. Excessive drain will damage the batteries and shorten their life.

### 4.4 Backplane Distribution

4.4.1 The power distribution is incorporated into the backplane for the NT1 cage. Each pair of terminals has its own .5 amp PTC. When the PTC current limit has been exceeded the PTC heats up and goes to a large resistance. To reset the PTC you need to remove all current flow.

### 4.5 NT1 Card Cage

- 4.5.1 The NT1 card cage will hold 12 NT1P230's . Power and signal get to the NT1 via connectors mounted at the rear of the card cage.

#### 4.6 **Distribution and Connectors**

- 4.6.1 All telco signals enter through a standard 25 pair telco connector "U" interface. These connectors are located on the left side of the PoweRack300. Mating to this interface requires a 25 pair male connector on the cable.
- 4.6.2 All terminal signals exit through a standard 25 pair telco connectors. These connectors provide the power and signal for the terminal equipment. Each rack has 2 of these connectors, which are located on the left side of the unit.
- 4.6.3 The power cord enters directly into the unit on the right side.
- 4.6.4 External Batteries are connected through a standard two pin locking connector. A connector is located on the right side wall, and plug in from the right. The mating cable should have male pins inside of a male housing.
- 4.6.5 External Alarm is provided through a standard RJ11 modular connector. This connector is attached to a set of form C contacts. This presents both the make and break contacts to the connector. This connector is located on the right side wall, and plugs in from the right. The mating connector should be a 6 conductor Male RJ11 plug.

# REPAIR AND MAINTENANCE

## 5.1 **Repair and Maintenance**

- 5.1.1 The PoweRack230 is an integrated telecommunications power supply with NT1 card cage(s). This unit has been designed to operate unattended and with a low maintenance overhead for extended periods of time. Although the electronics within the PoweRack 230 requires no routine maintenance, system voltage should be maintained within set limits to ensure maximum life of the battery pack. It is recommended therefore that this should be checked at least on a yearly basis and reset as necessary.

## 5.2 **Tools and Test Equipment**

- 5.2.1 No special tools other than those normally contained in an electronic technicians toolkit are required to service the PoweRack230. To check the system voltage and reset as necessary, it is recommended that a quality digital voltmeter be used.

## 5.3 **Rectifier/Charger - Output Voltage Adjustment**

- 5.3.1 The rectifier/Charger used in the PoweRack230 is a constant voltage/current limited device, which allows it to be safely used for battery charging as well as providing power to the load. What this means is, that if the load being drawn from the unit is minimal, then the output voltage will be constant. If however the current being drawn is excessive (as can happen during the recharge of a fully discharged battery), the voltage will be reduced and limit the current to the terminals.
- It is essential therefore that the final output voltage adjustment should only be done with a fully charged battery. Ensure that all battery packs, both internal and external are properly connected. Do not perform power supply adjustment if there has been a recent power failure. Allow 24 hours for batteries to be recharged.

# TROUBLESHOOTING

## 6.1 Troubleshooting

6.1.1 The attached instructions will help you determine the problem and correctly devise the solution to the most common problems found.

6.1.2 **QUESTION** - I have just installed the system. All lines are hooked up. However I have **no Indicators on the front panel.**

**ANSWER** - You will need to check the following items:

- a. Check the power cord at the wall service outlet. Make sure it is plugged in all of the way.
- b. Go to the circuit breaker box and check the circuit breaker is on.
- c. Using your voltmeter check the voltage at the wall service outlet. This voltage should be between 92 and 132 volts AC.
- d. Check the fuses on the power supplies.

6.1.3 **QUESTION** - I have just installed the system. All of the lines are hooked up. I have front panel indicators. However the **NT1's do not light up.**

**ANSWER** - You will need to check the following:

- a. Make sure that all of the NT1's are installed into the cage securely.

6.1.4 **QUESTION** - I have just installed the system. All of the lines are hooked up. I have front panel indicators. **All NT1's show power indication except for 1, of the NT1'S.**

**ANSWER** - You will need to check the following:

- a. Disconnect the terminals connected to this NT1.
- b. Unplug the NT1. Inspect the connectors for shorted pins. (This would be a pin, which are bent over so two adjoining pins touch.)
- c. Reinsert the NT1. If power indications are not on, unplug and swap with working NT1.
- d. NT1 power indicator is on. Reconnect one terminal at a time. When power is lost remove last terminal connected and check for a short on the Tx and Rx pairs, (PS1 power).

6.1.5 **QUESTION** - I have just installed the system with all of the lines are hooked up. I have a Normal front panel indicator and all NT1's show power indication. **NT1 2 shows terminal error (slow flash.)**

**ANSWER** - You will need to check the following:

- a. Swap with a working NT1.
- b. Is there a cable in the output connector for terminal 2?

- c. Is there a terminal wired to terminal 2?
  - d. At the user location is there a terminal in the terminal 2 position.
  - e. Is there a short on terminal 2 power (check both PS1 and PS2)?
- 6.1.6 **QUESTION** - I have just installed the system. All of the lines are hooked up. I have front panel indicators. All NT1's show power indication. **NT1 7 shows line error (Fast Flash).**
- ANSWER** - You need to check the following:
- a. Swap with a working NT1.
  - b. Check to see if there is a cable on the input connector for line 7.
- 6.1.7 **QUESTION** - The system has been up and running. Everything was working fine. We just had a power outage and the **system crashed**. We had a power outage last week but at that time the system worked fine.
- ANSWER** - You need to check the following:
- a. Check the circuit breaker for the unit and see if it has tripped.
  - b. Check front panel indicators. The green indicator should be on.
  - c. With a voltmeter check the voltage at the external battery connector. You should have 48.7 to 49 volts DC for a PR230.
  - d. Remove the battery fuse from the right side of the unit and check to see if it has blown.
- 6.1.8 Further investigation into the unit requires a trained technician who is more familiar with the system and its operation.

If you have a specific question not addressed in this manual, please call 1-800-765-4SEI and ask for technical support.

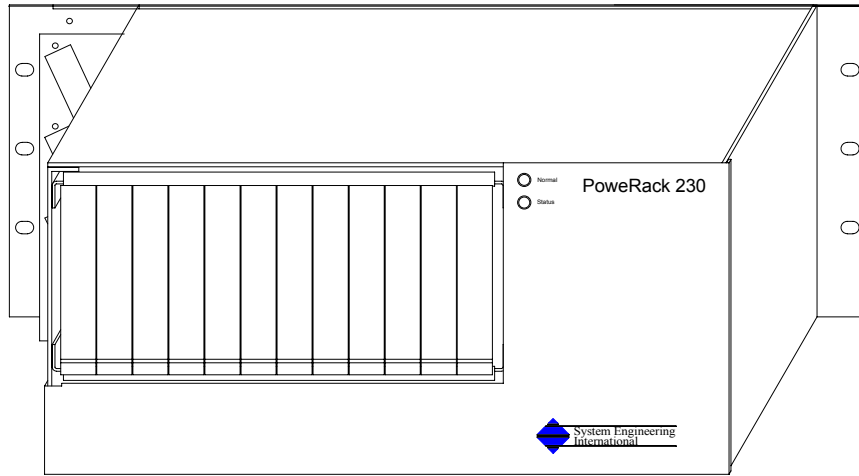

Figure PR230-24

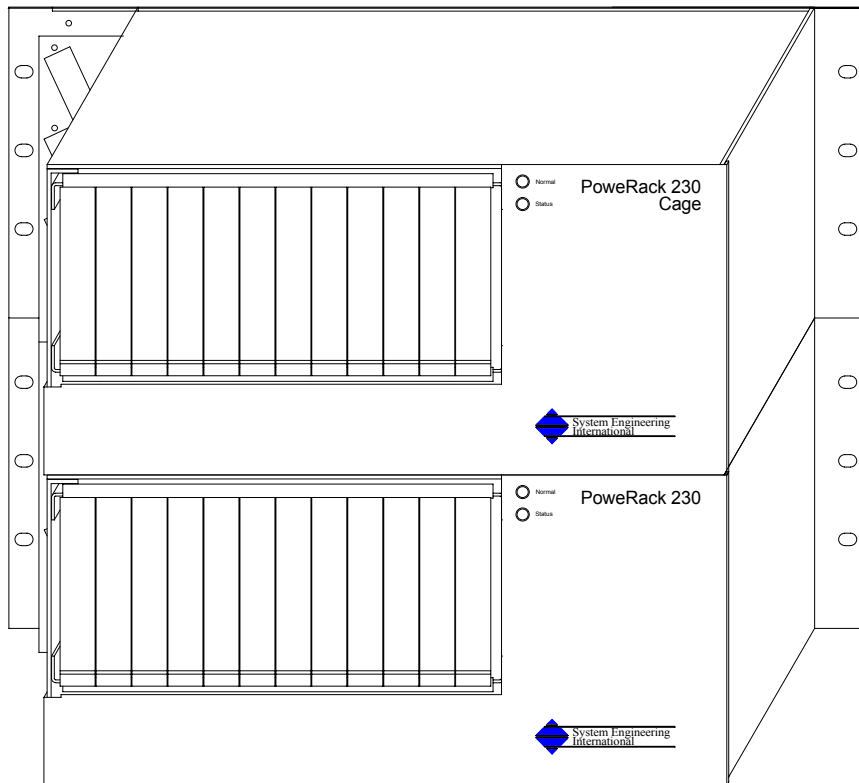
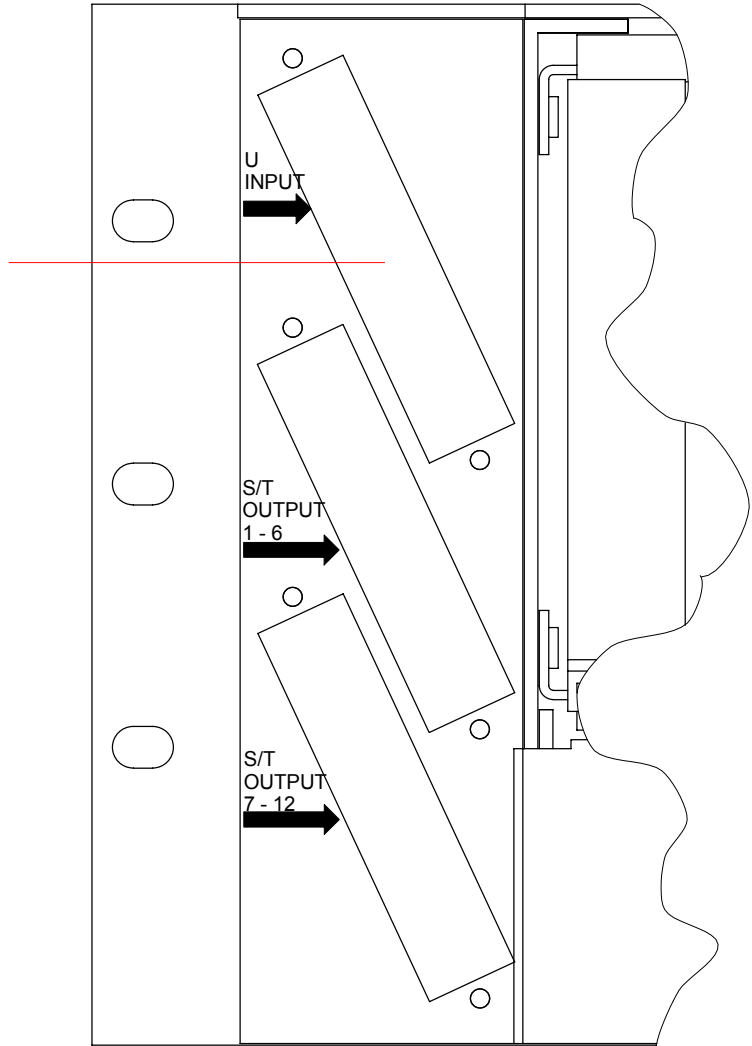

Figure PR230-48

## Appendix A

Wire Color	Signal	Wire Color	Signal
Blue/White	Ring	White/Blue	Tip
Orng/White	Ring	Wht/Orng	Tip
Grn/White	Ring	Wht/Grn	Tip
Brn/White	Ring	Wht/Brn	Tip
Slate/Wht	Ring	Wht/Slate	Tip
Blu/Red	Ring	Red/Blu	Tip
Orng/Red	Ring	Red/Orng	Tip
Grn/Red	Ring	Red/Grn	Tip
Brn/Red	Ring	Red/Brn	Tip
Slate/Red	Ring	Red/Slate	Tip
Blu/BLk	Ring	Blk/Blu	Tip
Orng/Blk	Ring	Blk/Orng	Tip
Grn/BLk	Not Used	Blk/Grn	Not Used
Brn/Blk	Not Used	Blk/Brn	Not Used
Slate/Blk	Not Used	Blk/Slate	Not Used
Blu/Yel	Not Used	Yel/Blu	Not Used
Orng/Yel	Not Used	Yel/Orng	Not Used
Grn/Yel	Not Used	Yel/Grn	Not Used
Brn/Yel	Not Used	Yel/Brn	Not Used
Slate/Yel	Not Used	Yel/Slate	Not Used
Blu/Vio	Not Used	Vio/Blu	Not Used
Orng/Vio	Not Used	Vio/Orng	Not Used
Grn/Vio	Not Used	Vio/Grn	Not Used
Brn/Vio	Not Used	Vio/Brn	Not Used
Slate/Vio	Not Used	Vio/Slate	Not Used



U Input Connections  
Wiring configuration  
PR230

Appendix B Figure 1

Wire Color	Signal	Wire Color	Signal
Blue/White	TX+	White/Blue	TX-
Orng/White	Spare	Wht/Orng	Spare
Grn/White	RX-	Wht/Grn	RX+
Brn/White	Gnd	Wht/Brn	-48
Slate/Wht	TX+	Wht/Slate	TX-
Blu/Red	Spare	Red/Blu	Spare
Orng/Red	RX-	Red/Orng	RX+
Grn/Red	Gnd	Red/Grn	-48
Brn/Red	TX+	Red/Brn	TX-
Slate/Red	Spare	Red/Slate	Spare
Blu/BLk	RX-	Blk/Blu	RX+
Orng/Blk	Gnd	Blk/Orng	-48
Grn/BLk	TX+	Blk/Grn	TX-
Brn/Blk	Spare	Blk/Brn	Spare
Slate/Blk	RX-	Blk/Slate	RX+
Blu/Yel	Gnd	Yel/Blu	-48
Orng/Yel	TX+	Yel/Orng	TX-
Grn/Yel	Spare	Yel/Grn	Spare
Brn/Yel	RX-	Yel/Brn	RX+
Slate/Yel	Gnd	Yel/Slate	-48
Blu/Vio	TX+	Vio/Blu	TX-
Orng/Vio	Spare	Vio/Orng	Spare
Grn/Vio	RX-	Vio/Grn	RX+
Brn/Vio	Gnd	Vio/Brn	-48
Slate/Vio	Unused	Vio/Slate	Unused

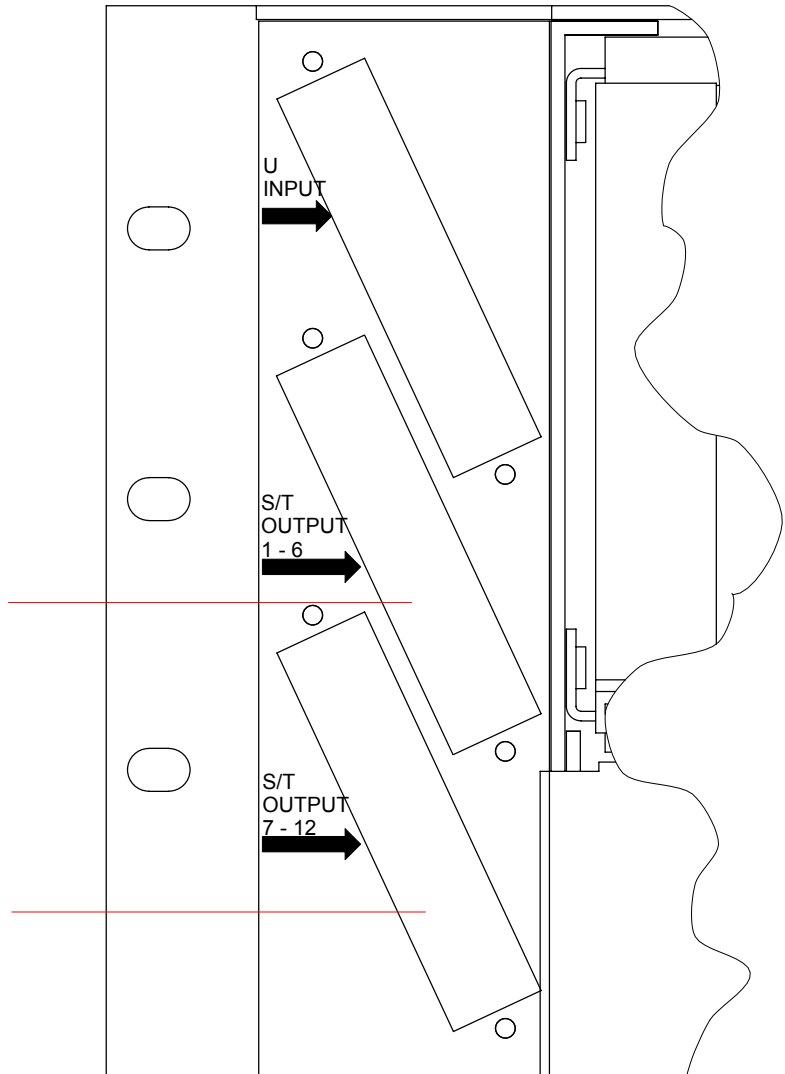

S/T Output Connection  
Wiring Configuration  
PR230

Appendix B Figure 2

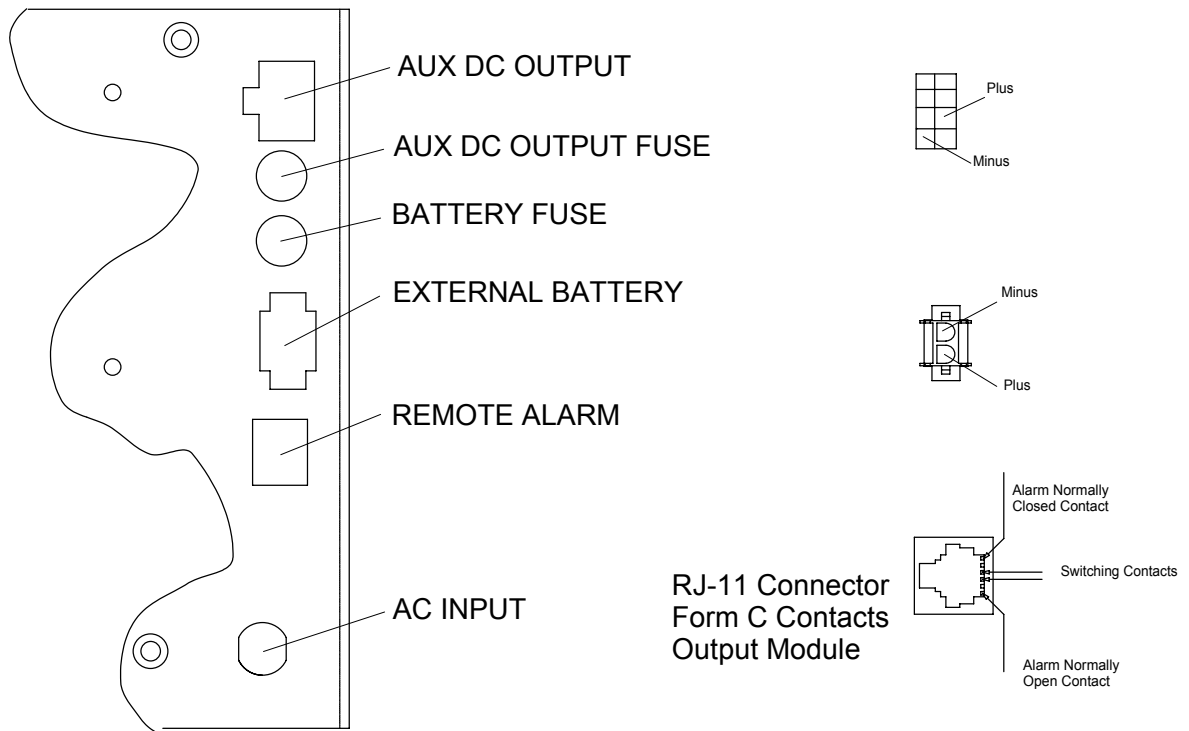

PR230 Right Side  
Connector Configuration